

ENG

PRESTIGE *Fietsen*

MANUAL
BAFANG MAX



PREFACE

My brand new electric beauty

You are the proud owner of a Prestige electric bicycle.

The bicycle is provided with electronic pedal assistance which guarantees a completely new way of cycling. The pedal assistance makes cycling lighter and more comfortable than ever.

Whether you use the bike for commuting, heavy shopping or just to get around, it is as if you always have the wind in your sails. Thanks to the reliable, durable and easy to operate electronic pedal assistance, exertion is now relaxation!

Chances are you have not owned a bicycle with electric pedal assistance before. So please read our manual first to learn more about your electric bike, how to use the LCD display, and to get even more facts and tips. For more information or the latest news, please visit our website:

www.prestigefietsen.be

CONTENT

Exploring the display	4
Explore the control panel	5
Operating the display	5
Bike range and battery capacity	7
Disconnecting and removing the battery	7
Battery charging and more info	7
Pedal assistance	8
Tire pressure	10
Shifting gears	10
Checking your bike and tips	10
Cleaning and treatment	11
Service and inspection	11
Warnings	12

I. EXPLORING THE DISPLAY

The display only works when the battery is in the bike and the battery is on.

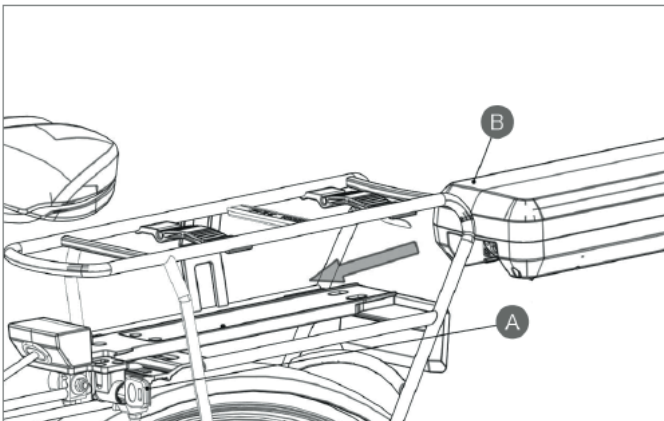

- A** battery pack lock
- B** battery

Insert the battery from the back between the opening and push it gently forward until you hear a click. Remember to securely lock your battery before you start driving.

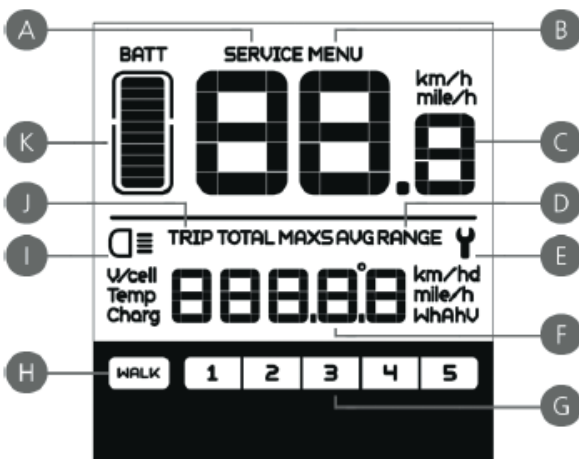

- A - When it is necessary to carry out a service the SERVICE symbol will appear on the screen. Please make an appointment with Prestige for main tenance.
- B - Menu
- C - Speed display in km/h or mile/h
- D - Speed mode : average speed (AVG km/h) maximum speed (MAXS km/h)
- E - Error display: when an error occurs, the symbol of the symbol of a wrench will appear.
- F - Distance display (distance travelled)
- G - Speed modes from 1 to 5 (1: minimum support - 5: maximum support) 5: maximum assistance)
- H - Walk assist: While walking and pushing the bike, 'WALK
- I - Lighting: This symbol appears when your front and rear lights are on. back light are on.
- J - Distance mode / TRIP: the distance of the ride.
TOTAL: the total distance you have already covered.
- K - Battery indication

2. EXPLORE THE CONTROL PANEL



- A - more assistance / up
- B - less assistance / down
- C - lighting
- D - switch on / off
- E - mode / menu

3. OPERATING THE DISPLAY

Turning On/Off

Press the power button for 2 seconds to start the display. Press the power button for 2 seconds to turn off the display. When the pedelec is not used for 5 minutes the display will turn itself off.

Gear Mode

In the manual gear mode you can use the + and - buttons to get the desired support. In level 0 the bicycle will not provide any support. In level 1 the bicycle will give the minimum support and in level 5 the maximum support.

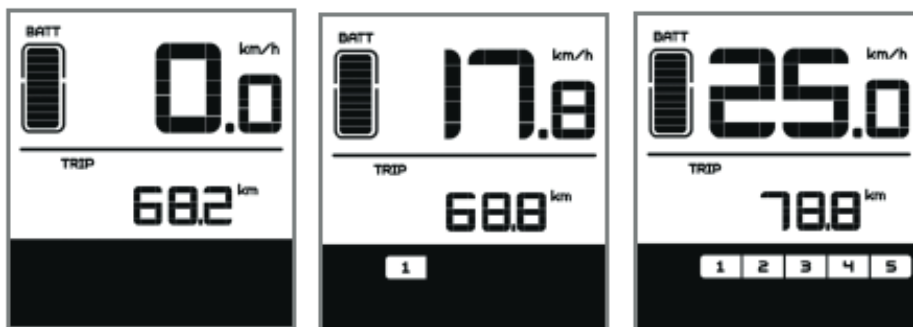

Switching between speed menu and distance menu

Press the "i" or menu button briefly to switch between the speed menu and the distance menu.

TRIP (km): the distance of the driven trip. (now)

TOTAL (km): the total ride distance of the bicycle (over the entire period)

MAXS (km/h) maximum ridden speed

AVG (km/h): average of the ridden speed



Front light and display light

Press the button for 2seconds 

The display light, front light and rear light will turn on.

Press the button for 2 seconds: to turn the lights off again. 

(When the display is in a dark environment, it will automatically turn on the front light,

(When the display is in dark surroundings, it will automatically turn on the front light, back light, and display. If the lights are turned off manually (by pressing the button), they will have to be turned on again manually and will not turn on automatically.) There are 5 settings for the backlight to adjust the brightness of the screen.

Walking assistance

Press and hold the “-” button. This will put us into the walk assist mode and the WALK symbol will appear on the screen. When you release the “-” button the e-bike will end the walk assist mode.

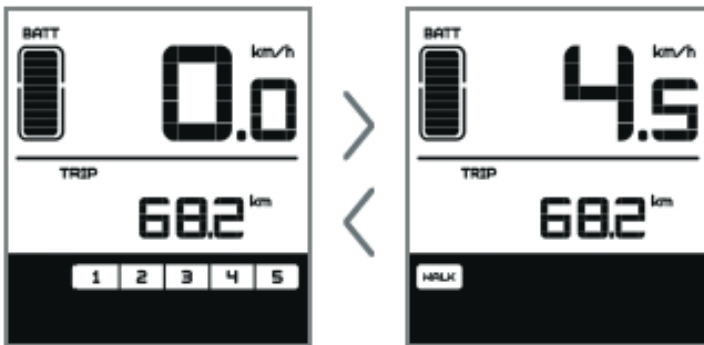

No walking assistance

Walking assistance on



Caution! Only use the walking assistance when you are standing firmly beside the bike and there is a (slightly) sloping surface. Keep at least one hand on the brake. The Walking Assistance function has a speed of 6km/h

Battery indication

When the battery is fully charged, the 10 segments will be colored completely black.

As the battery decreases in size, fewer segments will turn black. When the battery is completely empty and needs to be recharged urgently the 10 segments will be empty and the black edge of the battery will start to light up.

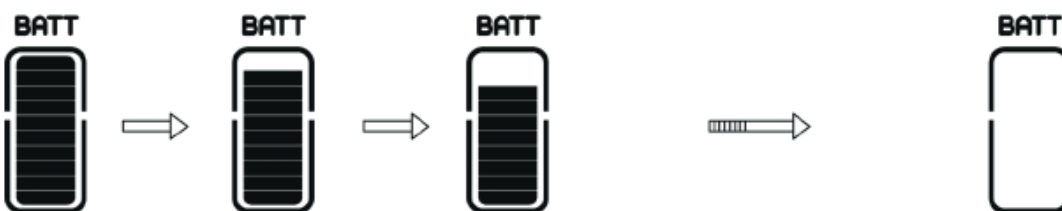

4. BIKE RANGE AND BATTERY CAPACITY

How long is the range of my electric bike?

The total distance you can ride with your Prestige e-bike without recharging is called the range. To properly assess this, leave the bike/battery on the charger overnight. The range should be measured during one ride and not spread over several days. Batteries discharge slowly, even when the bike is not being used. When the battery is in the bike, it discharges faster than when it is removed from the bike and left inside.

Factors

Influencing factors action radius:

- *The total weight (weight of bike + rider + load)*
- *The resistance (wind force, tire pressure, acceleration, road surface condition and height differences)*

The pedal power level:

- *Your driving behavior (timely up- and downshift and the speed driven)*
- *The outdoor temperature*
- *Age of battery (Battery capacity decreases as battery ages)*

5. DISCONNECTING AND REMOVING THE BATTERY

Disconnecting and removing the battery

On the left front of the pack carrier is the battery lock. This allows you to lock the battery pack to the bike or disconnect it from the bike.

To unlock the lock: Insert the key into the lock and turn it counterclockwise.

Use the handle on the back to pull the battery pack out from under the rack.

CAUTION! Remove the key after putting back the battery, in connection with  possible loss and/or theft of the key and battery.

6. BATTERY CHARGING AND MORE INFO

Battery charging

With the included charger you can charge the battery. You can charge the battery pack either on the bike or separately from the bike. Place the charger in the left rear corner of the battery pack. The initial charging time for the Prestige battery is approximately 7 hours. During charging a red light will light up. When the battery is fully charged, this light will be green.

! **CAUTION!** Disconnect the charger when the battery is charged. This will prevent the battery life from being shortened.

! **CAUTION!** If the battery is not used for a long time, it may suffer irreparable damage. Be sure to charge the battery every 3 weeks for half an hour.

! **CAUTION!** If the bike is not used for a long time, we recommend removing the battery from the bike.

! **CAUTION!** Use your battery charger only in dry, well-ventilated areas.

! **CAUTION!** The battery charger is not resistant to moisture and/or drop shocks.

! **CAUTION!** When the battery is completely empty, charge it immediately. If cells are left empty for a long time, they may be damaged beyond repair.

What else you should know about your battery.

Try to ride your electric bicycle as much as possible, if you don't use it enough the battery could discharge and break down. Also try to ride it 2 months a year in the winter months.

The battery is splashproof and therefore resistant to rain. You can therefore use your bike in bad weather.

However, do not expose the battery to large amounts of water.

The performance of your battery will decrease at low temperatures.

Do not expose the battery to high temperatures (> 50 °C), such as heating, direct sunlight and fire.

Do not disassemble the battery. Consult the dealer in case of problems. For long-term storage, place the battery in a shady, cool and dry place. Use only the supplied charger.

7. PEDAL ASSISTANCE

What is pedal power?

The bike is equipped with electric pedal assistance. The motor supplements your own efforts, increasing your performance while providing less power.

The effect of the pedal assistance depends on the speed at which the pedals are turned and the

The pedal assistance function depends on the speed at which the pedals are rotated and on the speed of the bicycle. If there is no pedaling, the motor does nothing. If you start up, the motor provides a lot of support so you can easily get going.

be helped to get going.

8. TIRE PRESSURE

Tire pressure affects the range and comfort of your bicycle.

It is advisable to always inflate your tires hard. Hard means that you should be able to (4 to 5bar) On the side of all tires you can find the maximum tire pressure.

This tire pressure is expressed in Bar. When inflating your tire we advise you to use a bicycle pump that is equipped with a tire pressure gauge.

9. SHIFTING GEARS

The bike is equipped with derailleur gears. You can operate the gears by turning the inside of the right handlebar while cycling. Do not shift more than one gear at the same time.

Using your gears:

Derailleur gear: Do not change gears while standing still, and definitely do not pedal backwards while changing gears

10. CHECKING YOUR BIKE AND TIPS

Prestige Bicycles recommends that you have your bicycle checked regularly by your dealer.

It is advisable to have the first service performed within 3 months and the second after 1 year.

1 year. Remember that by checking your bike regularly, you can avoid a lot of unnecessary damage in the long run and therefore also a lot of unnecessary costs!

Of course you can also contribute to keeping your bike in top condition for as long as possible.

The following paragraphs provide some tips.

General maintenance

- 1 Check tire pressure and tread
- 2 Check the wear of the brakes, occasionally adjusting the fine adjustment
- 3 Clean pedal sensor with sponge and lukewarm water in case of severe dirt
- 4 Lubricate the chain
- 5 If a wheel strikes, have it repaired immediately by the dealer.

II. CLEANING AND TREATMENT

Cleaning your bicycle

You can clean your bike by first removing the dirt with a brush and then washing it with warm water. This will make your bike look like new again. Regular cleaning of the bicycle will increase its service life. Be careful not to use too much water near the battery. Make sure that no dirt gets into the sensor plate (near the bottom bracket). When cleaning the bike, it is best to remove the battery. Never use a high-pressure cleaner!

Treatment

In addition to regular cleaning, it is wise to treat certain parts immediately after cleaning. For example, we recommend greasing chromed parts, unpainted aluminum and stainless steel parts with acid-free petroleum jelly to prevent oxidation (rust). Rotating parts need grease/oil.

It is recommended that the chain, it is recommended to lubricate the chain, sprockets and axles regularly. Your dealer can do this for you.

12. SERVICE AND INSPECTION

1st service - 250km - or after 3 months

Check wheels and tires.

(Beats in the wheels, spokes tension, tire profile).

Check all fixing parts, tighten if necessary.

Brakes: Check brake pads for wear - Adjust cable tension -

Check brake operation.

Check headset for play - Check stem attachment - adjust if necessary.

Lubrication: Clean and lubricate chain with Teflon spray or silicone spray.

Electrical System: Charge the battery for 5 hours - Clean the pedal sensor with lukewarm water and a sponge - Treat the contacts with contact spray treat the contacts with contact spray - check that everything works correctly.

Derailleur - check that all gears are found smoothly, adjust if necessary

Check the following regularly:

Is the battery charged? Are the brakes still working as they should?

Are brake pads, bolts and nuts still tight? Are the cables not damaged?

Are the brake surfaces clean and free of grease? Are there any worn-out brake blocks?

Is my bike adjusted properly? Are the saddle and handlebar not above the maximum position? Is the angle of the handlebar comfortable?

Is my handlebar properly aligned with the front wheel?

Are my handgrips still secure?

Is the tension of my spokes still sufficient? Do I have a stroke in my wheel?

Are there any broken spokes? Do my tires have the right pressure?

Is there enough tread on my tires? Is the stem fixed properly?

Is my saddle tight? Is there no play in my wheels?

Do my lights work? Am I well visible in the dark?

Are the surfaces of the reflectors properly clean? Are the reflective strips on my tires present and if so, are they clean? Does the pedal assistance work properly?

Do the gears work as they should?

Is the chain tension correct? Is my bicycle not in need of a cleaning?

Have I recently serviced my bicycle?

13. WARNINGS

- *If you want to charge the battery, use only the supplied battery charger for this purpose.*
- *Use the battery only for your bicycle.*
- *Do not spray the bicycle clean with a high-pressure sprayer. A too powerful jet of water may damage the electronics of the bike. The warranty will be voided.*
- *If used improperly, you may endanger yourself and others. In addition, improper use voids the warranty.*
- *Do not use any battery for your bicycle other than the one provided by Prestige.*
- *Do not insert objects into the charger or expose both the charger and the battery and electronics to water or other liquids.*
- *For maintenance of your electric bicycle you can always contact your Prestige dealer.*

Enjoy your new electric bike! Get started and test it out !

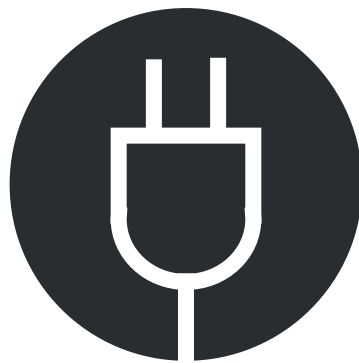

PRESTIGE *Fietsen*